

# STUDIO MATTE BOX SMB-1

USER GUIDE

17 December 2014

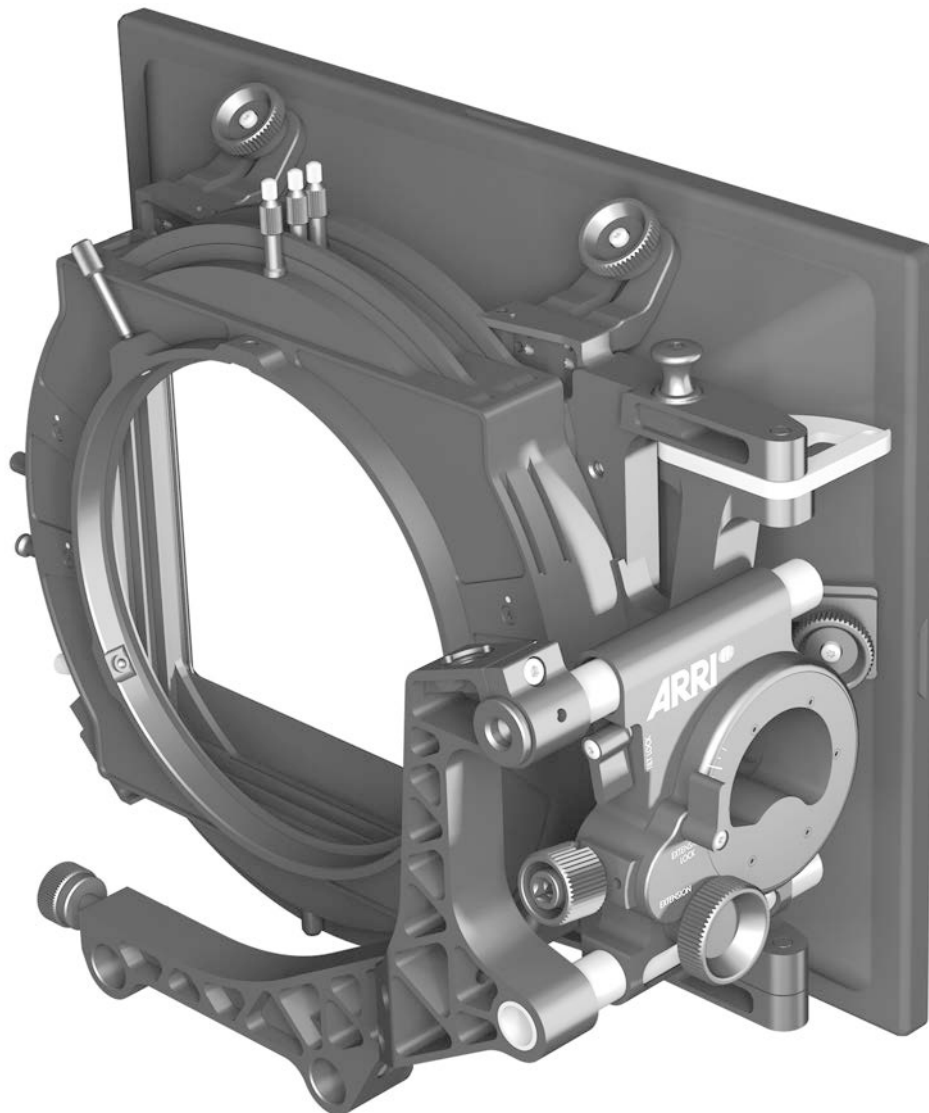

# Imprint

## Copyright

© 2014 Arnold & Richter Cine Technik GmbH & Co. Betriebs KG. All rights reserved. No portions of this document may be reproduced without prior written consent of Arnold & Richter Cine Technik GmbH & Co. Betriebs KG. Specifications are subject to change without notice. Errors, omissions, and modifications excepted.

Original version.

## For further assistance

Arnold & Richter Cine Technik GmbH & Co. Betriebs KG  
Tuerkenstr. 89  
D-80799 Munich, Germany  
E-mail: [service@arri.com](mailto:service@arri.com)  
[www.arri.com/service](http://www.arri.com/service)

## Document revision history

Version	ID	Release	Date
1.0	80.0003786	K08575	17 December 2014

# Contents

<b>1</b>	<b>Risk levels and alert symbols.....</b>	<b>5</b>
<b>2</b>	<b>Introduction.....</b>	<b>6</b>
<b>3</b>	<b>Available versions.....</b>	<b>7</b>
<b>4</b>	<b>Accessories.....</b>	<b>8</b>
<b>5</b>	<b>Compatibility.....</b>	<b>11</b>
<b>6</b>	<b>Tooling.....</b>	<b>12</b>
<b>7</b>	<b>Sunshade.....</b>	<b>13</b>
7.1	Mounting/Removing a sunshade.....	13
7.2	Anamorphic sunshade.....	14
<b>8</b>	<b>Swing-away system.....</b>	<b>15</b>
8.1	Opening a matte box with swing-away system.....	15
<b>9</b>	<b>Studio Arm.....</b>	<b>16</b>
9.1	Mounting/Removing a matte box studio arm.....	16
9.2	Fitting a matte box on rods.....	17
<b>10</b>	<b>Filter stages.....</b>	<b>18</b>
10.1	Fitting a group of filter stages.....	18
10.2	Separating two filter stages.....	19
10.3	Rotating the filter stages.....	20
10.4	Geared filter frame.....	21
10.5	Tray catcher.....	22
<b>11</b>	<b>Tilt and extension module.....</b>	<b>23</b>
11.1	Tilt module.....	23
11.2	Extension module.....	24
<b>12</b>	<b>Flags.....</b>	<b>25</b>
12.1	Mounting/Removing the top/bottom flag.....	25
12.2	Mounting/Removing a side flag.....	26
12.3	Adjusting the flag angle.....	26
12.3.1	Quick adjust.....	27
12.3.2	Fine adjust.....	27
<b>13</b>	<b>Mattes.....</b>	<b>28</b>
13.1	Inserting a matte.....	28
13.2	Fitting a protective cover (matte #0).....	29

<b>14</b>	<b>Accessory adapter.....</b>	<b>30</b>
14.1	Mounting/Removing an accessory adapter.....	30
14.2	Adapter operation.....	31
<b>15</b>	<b>6" Tilting filter ring.....</b>	<b>32</b>
15.1	Mounting/Removing the 6" tilting filter ring.....	32

# 1 Risk levels and alert symbols

Safety warnings, safety alert symbols, and signal words in these instructions indicate different risk levels:

## **▲ CAUTION!**

*CAUTION* indicates a potentially hazardous situation which, if not avoided, **may result in** minor or moderate injury.

## **NOTICE**

*NOTICE* explains practices not related to physical injury. No safety alert symbol appears with this signal word.

## 2 Introduction

The Studio Matte Box SMB-1 supports filter sizes up to 6.6" x 6.6". It is designed for use with bigger wide-angle prime lenses and also with zooms.

The SMB-1 Tilt has an exclusive integrated tilt module and all versions benefit from stackable filter stages, allowing quick reconfiguration.

Uniquely, both 4:3 and 2:1 ratio sunshades are available, optimized respectively for spherical and anamorphic filming.

The Studio Matte Box SMB-1 covers the full ALEXA sensor area and allows the Master Prime 12 mm to be used with a 2-filter stage, the Ultra Prime 10 mm with a 1-filter stage, and the Ultra Wide Zoom UWZ 9.5-18 mm with a 1-filter stage.

### 3 Available versions

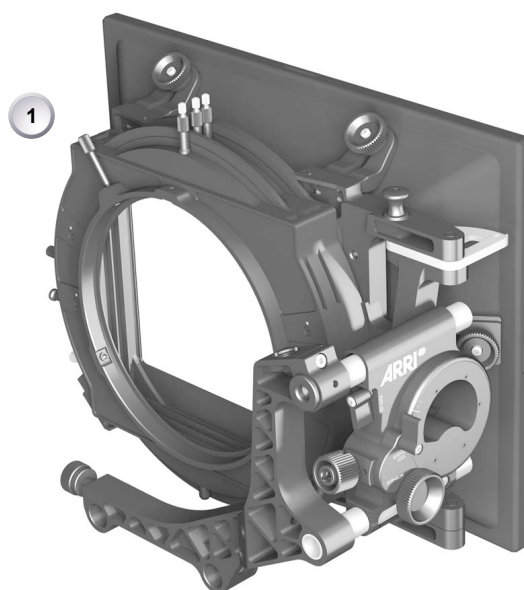

1	SMB-1 Tilt	K2.66262.0
2	SMB-1 Basic	K2.0001516

## 4 Accessories

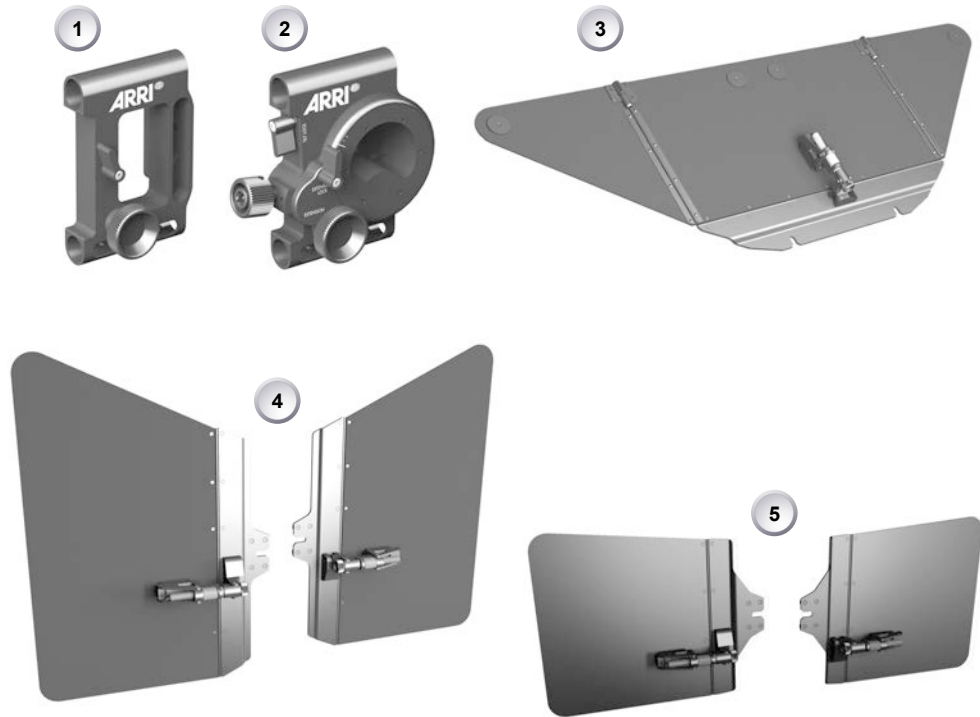

1	Extension Module	K2.0001519
2	Tilt and Extension Module	K2.0001520
3	Top/Bottom Flag	K2.66273.0
4	Side Flags (pair)	K2.66274.0
5	Side Flags ANAM (pair)	K2.0001173



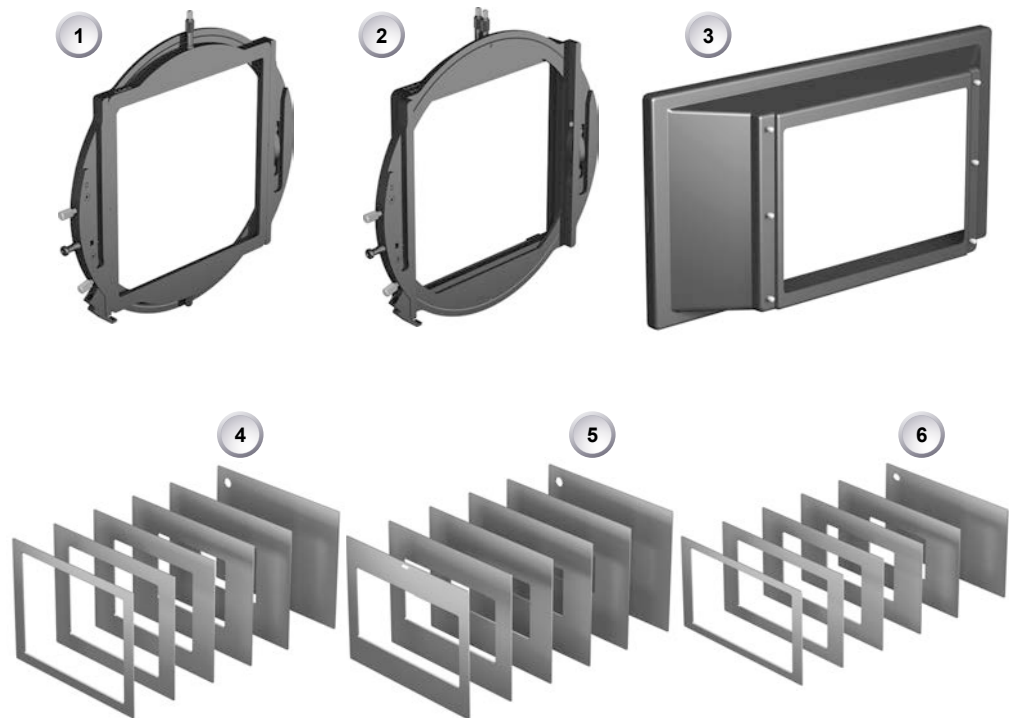

<b>1</b>	1-Filter Stage incl. 1 x Filter Frame, non-geared	K2.0001462
<b>2</b>	2-Filter Stage incl. 1 x Filter Frame, non geared and 1 x Filter Frame, geared	K2.0001465
<b>3</b>	Sunshade ANAM	K2.0001466
<b>4</b>	Mattes SPH	K2.66267.0
<b>5</b>	Mattes SPH/ANAM	K2.0001161
<b>6</b>	Mattes ANAM	K2.0000676

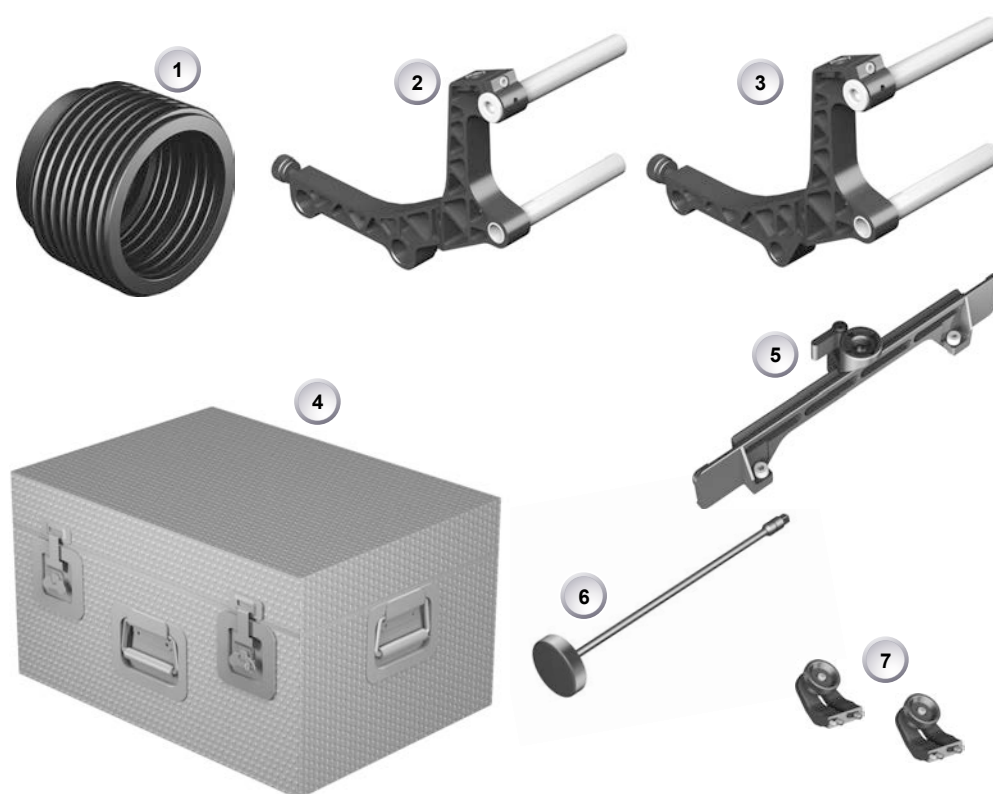

1	6" Tilting Filter Ring Ø150 mm	K2.0001174
2	19 mm Studio Arm	K2.66280.0
3	15 mm Studio Arm	K2.0000646
4	Case for SMB-1	K2.0002669
5	Accessory Adapter	K2.0001172
6	Flexible Shaft	K2.34890.0
7	Top/Bottom Flag Holders (pair)	K2.0001517

## 5 Compatibility

The Studio Matte Box is compatible with the following ARRI accessories:

- All R1 rings 165 mm - check details online with ARRI Configuration Overviews
- All F1 filter frames - check details online with ARRI Configuration Overviews

## 6 Tooling

### **NOTICE**

All fastening screws necessary for matte box operation are fitted with a 3 mm Hex driver.

The dismantling of matte box components fastened with Torx head screws is not covered in this manual. We recommend contacting an ARRI Service partner.

#### **Tools needed**

- 1 x 3 mm Hex driver

## 7 Sunshade

The sunshade of the matte box can be removed for special applications.

An optional sunshade designed for anamorphic filming is available (K2.0001466). This sunshade is part of the Anamorphic Upgrade Set (K0.0001676).

### 7.1 Mounting/Removing a sunshade

Remove the sunshade in order to fit the anamorphic sunshade or for special applications when no sunshade is desired, such as with macro shots.

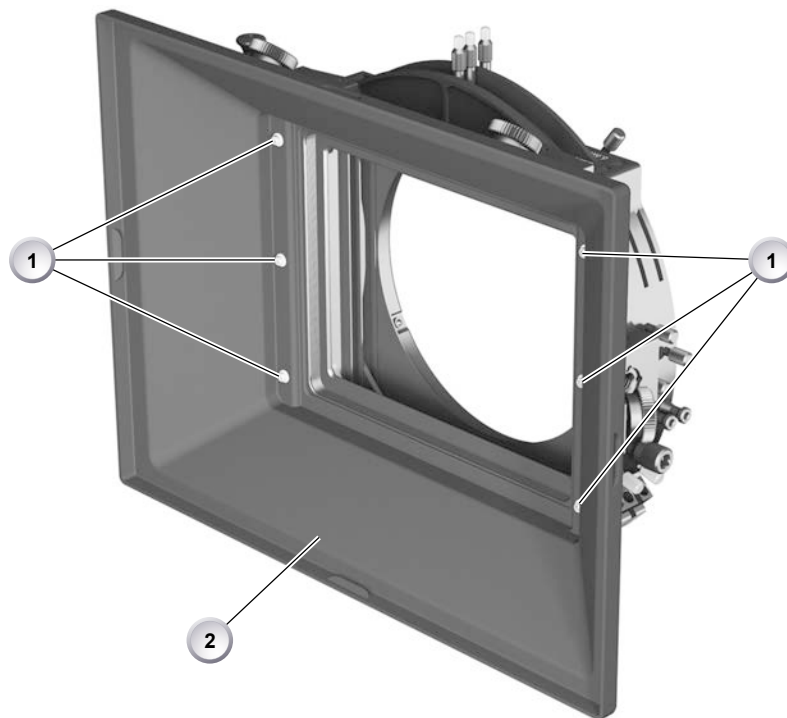

1. Fit the matte box to the camera rods or rest the matte box on its back.
2. **To remove:** Hold the sunshade (2) to the matte box and loosen all six screws (1).  
**Note:** The screws (1) should stay captive in the sunshade (2).
3. Remove sunshade (2).
4. **To mount:** Tighten all six screws (1).

## 7.2 Anamorphic sunshade

You can optimize the matte box for anamorphic filming with a 2:1 ratio sunshade, side flags and matte set. The standard 4:3 ratio sunshade covers the full ALEXA sensor and permits repositioning in post-production.

The optional Anamorphic Upgrade Set comprises a 2:1 ratio sunshade, a pair of side flags and a set of mattes matching the 2:1 ratio sunshade.

<b>SMB-1 Anamorphic Upgrade Set</b>	<b>K0.0001676</b>
Sunshade ANAM	K2.0001466
Side Flags ANAM (pair)	K2.0001173
Mattes ANAM	K2.0000676

### **NOTICE**

Each flag holder for the top and bottom flag can be repositioned by means of the two screws holding it to the matte box main frame in order to suit either the 4:3 or 2:1 sunshade.

## 8 Swing-away system

To facilitate lens change, you can open the matte box. The swing-away system locks automatically in a closed and opened position. This reduces the probability of lens damage during lens change.

### 8.1 Opening a matte box with swing-away system

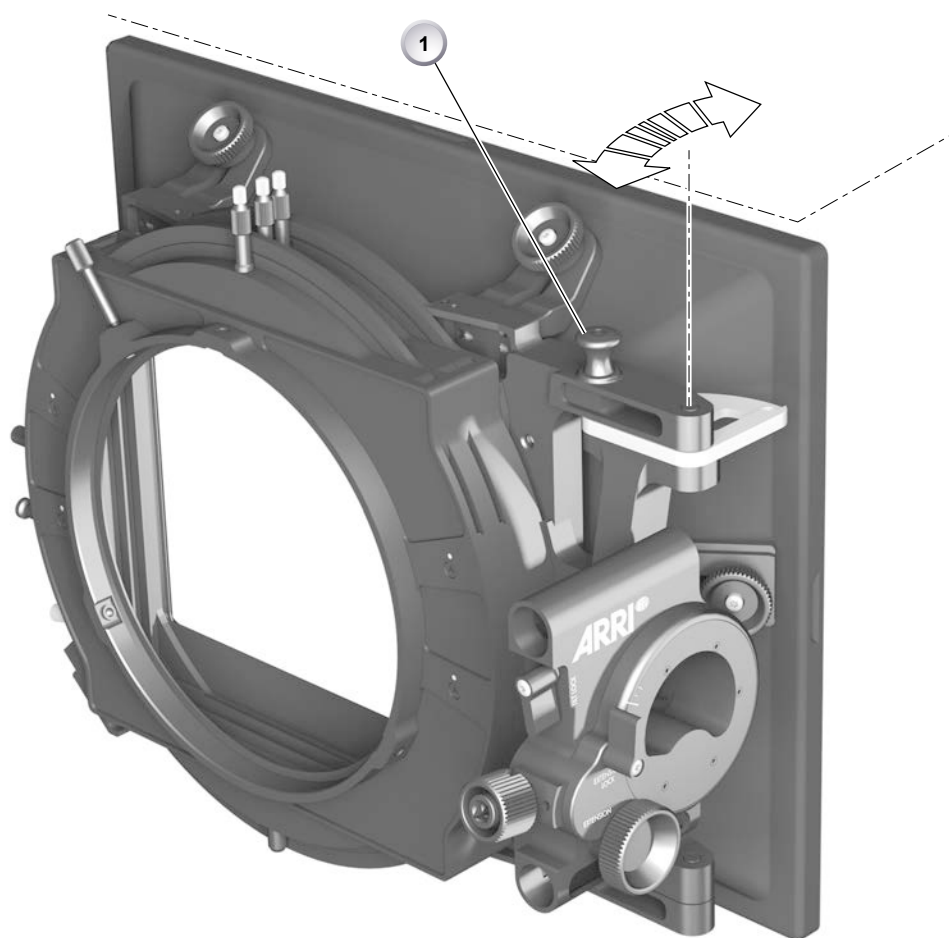

1. Fit the matte box to the camera rods.
2. If necessary, ease the lens rubber ring off the lens. Alternatively, extend the matte box with the extension module. See Page 24.
3. Pull the release plunger (1) while opening the matte box to the right of the camera until it locks automatically.
4. Change or clean the lens.
5. Pull the release plunger (1) and swing the matte box back onto the lens until it locks automatically.
6. Adjust the matte box extension if necessary.

## 9 Studio Arm

The Studio Matte Box is available with 19 mm and 15 mm matte box studio arms.

### NOTICE

The matte box can only be supported on 19 mm and 15 mm studio rod systems. A 15 mm lightweight support is not compatible.

### 9.1 Mounting/Removing a matte box studio arm

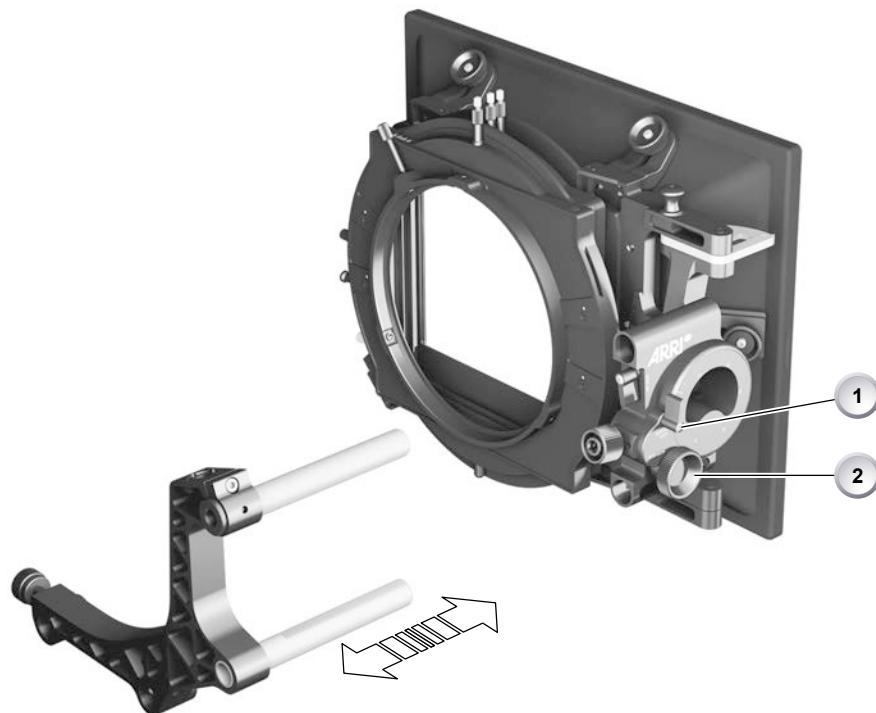

1. Rest the matte box on its sunshade.
2. Unlock the extension module (1).
3. Extend the matte box by rotating the extension knob (2) clockwise.
4. **To remove:** If fully extended, gently separate the matte box and arm.
5. **To mount:** Insert the matte box arm by rotating the extension knob (2) anti-clockwise and adjust the matte box extension if necessary.



## 9.2 Fitting a matte box on rods

The Studio Matte Box fits 19 mm or 15 mm studio camera systems.

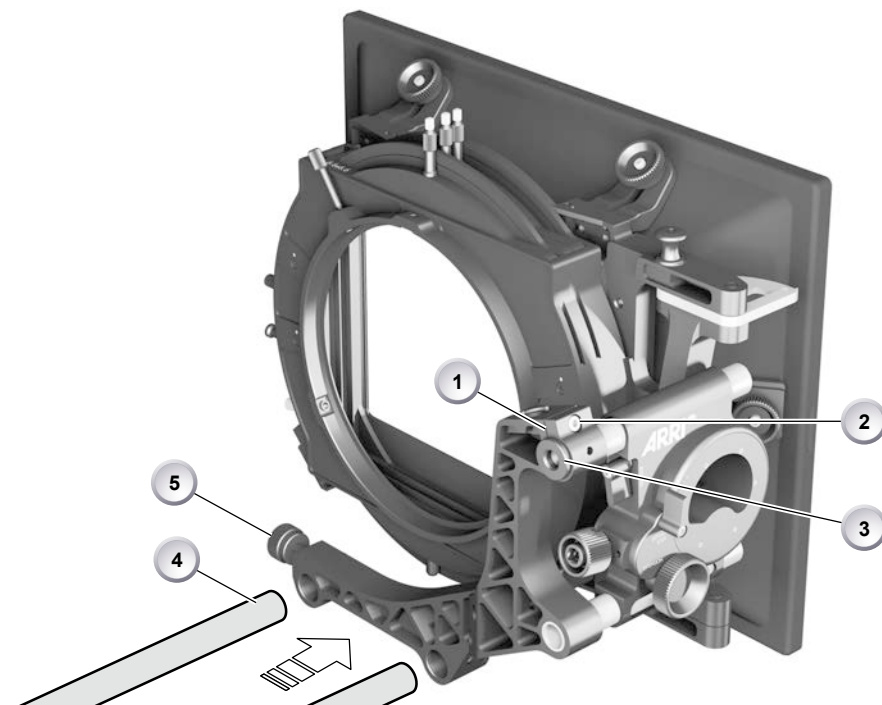

### NOTICE

Before fitting the matte box, install all rod-related accessories. Please ensure that fitting the matte box is the last step.

1. Unlock the studio arm console by turning the wheel (5) anti-clockwise.
2. Slide the matte box onto the rods (4) with the extension closed.
3. Lock both rods and the matte box by turning the wheel (5) clockwise.
4. You can now raise or lower the matte box:
  - Loosen the 3 mm hex screw (2) on top of the arm
  - Turn the height adjuster (3) with the same driver until you reach the required height
  - To reset to standard height: Align the white line on the adjuster (3) with the clamp slot (1) on top of the matte box arm

## 10 Filter stages

SMB-1 filter stages come in 1-filter and 2-filter modules.

- 1-filter stage modules come with one filter frame 6.6" x 6.6" (non-geared) and cannot accept geared filter frames.
- 2-filter stage modules come with two filter frames (one geared, one non-geared).

All filter stages are fitted with tray catchers.

All filter frames, non-geared, are compatible with the geared slot of the 2-filter stage.

### NOTICE

You can remove filter stages as a single module or in group.

### 10.1 Fitting a group of filter stages

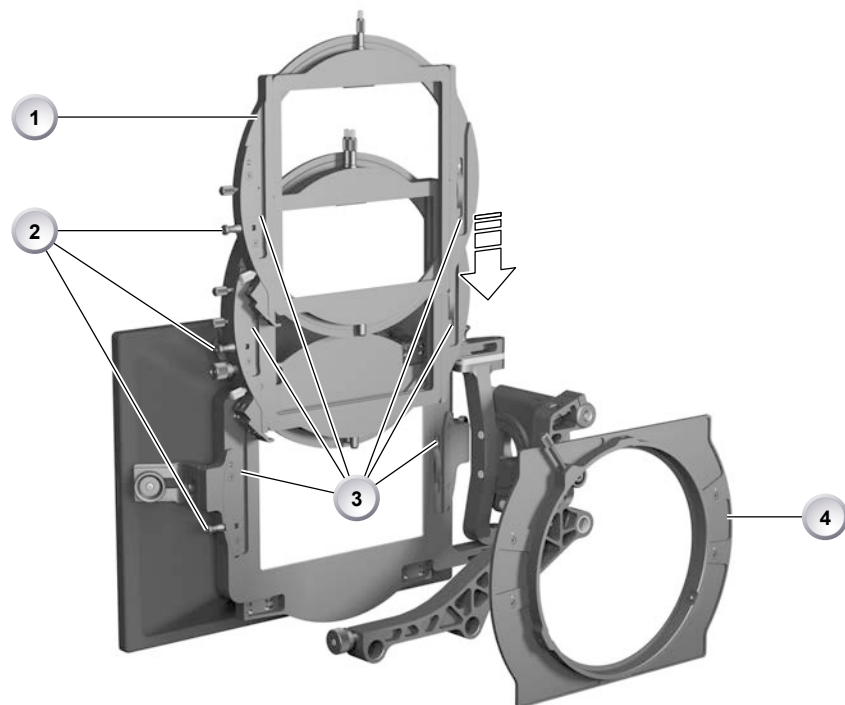

1. Remove the back plate (4) from the matte box if necessary:
  - Release the relevant release plunger (2)
  - Pull the back plate (4) upwards
2. Slide the group of filter stages (1) from the top of the matte box:
  - Ensure that all sliding guides (3) are fully engaged in their counterparts
3. Slide the filter stages (1) down until the release plunger (2) clicks.
4. Fit the back plate (4) at the back of the rear filter stage (1).

## 10.2 Separating two filter stages

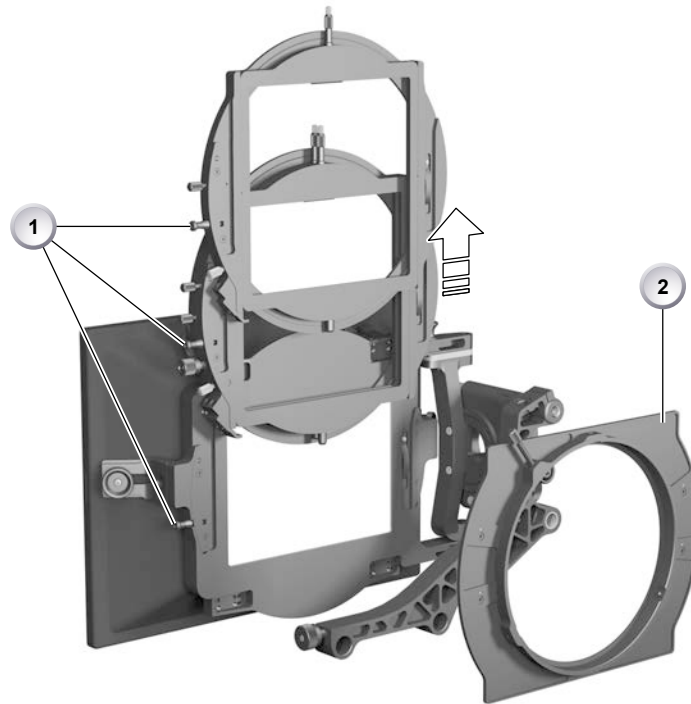

1. Pull the respective release plunger (1) .
2. Lift up and remove the redundant filter stage.
3. Reattach the back plate (2) to the remaining filter stage.

## 10.3 Rotating the filter stages

The filter stages can rotate independently. **Note:** Filter frames in 2-filter stages rotate in pairs.

### NOTICE

The filter stage features an anti-friction coating and should not be greased or oiled.

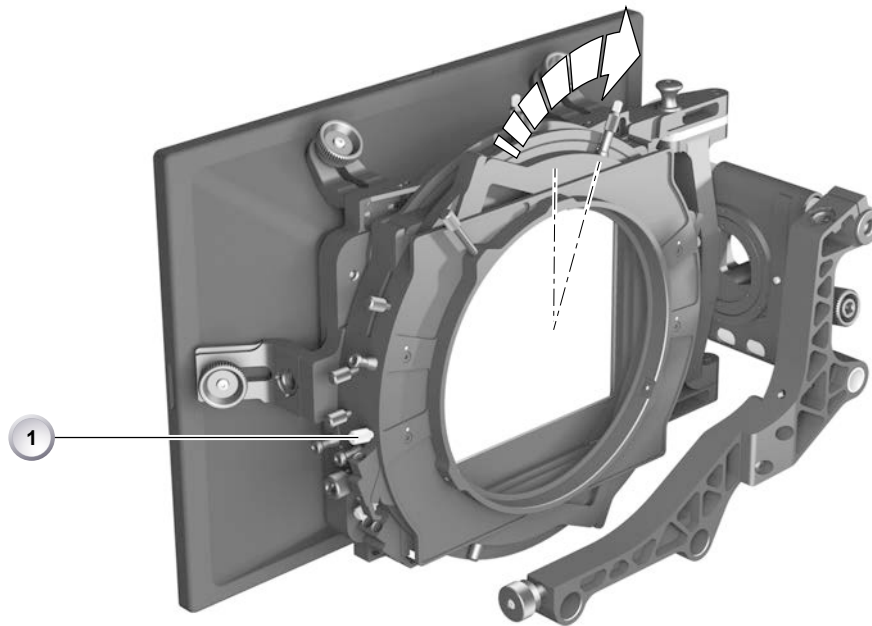

1. Fit the matte box to the camera rods.
2. Install the filter stages to the matte box.
3. Unlock the filter stage rotation by turning the rotation lock (1) anti-clockwise slightly.
4. Rotate the filter stage to the required angle.
5. Lock the filter stage rotation by turning the rotation lock (1) clockwise.

## 10.4 Geared filter frame

Graduated filters can be precisely adjusted by using the geared filter frames.

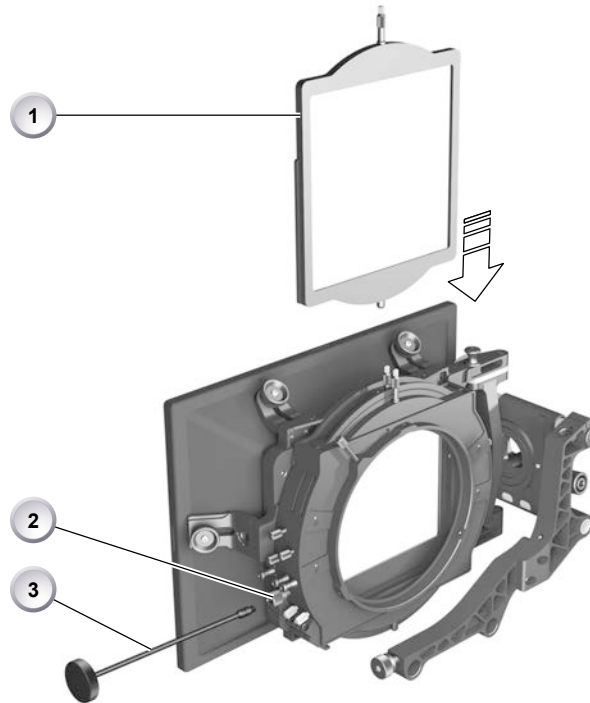

1. Place a graduated filter in the front filter frame (1) of a 2-filter stage module with the gear facing left.
2. Turn the graduated filter frame wheel (2) located on the side of the 2-filter stage under the stackable stage release plungers. This will lower or raise the geared filter frame.
3. In order to follow camera tilt movement without touching the camera rig, a flexible shaft (3) K2.34890.0 is available for step back adjustment.

## 10.5 Tray catcher

The tray catchers secure filter frames during intense filming such as vehicles and special effect shots.

### NOTICE

Do not force filter frames down when tray catchers are in use. This could result in damage to the matte box.

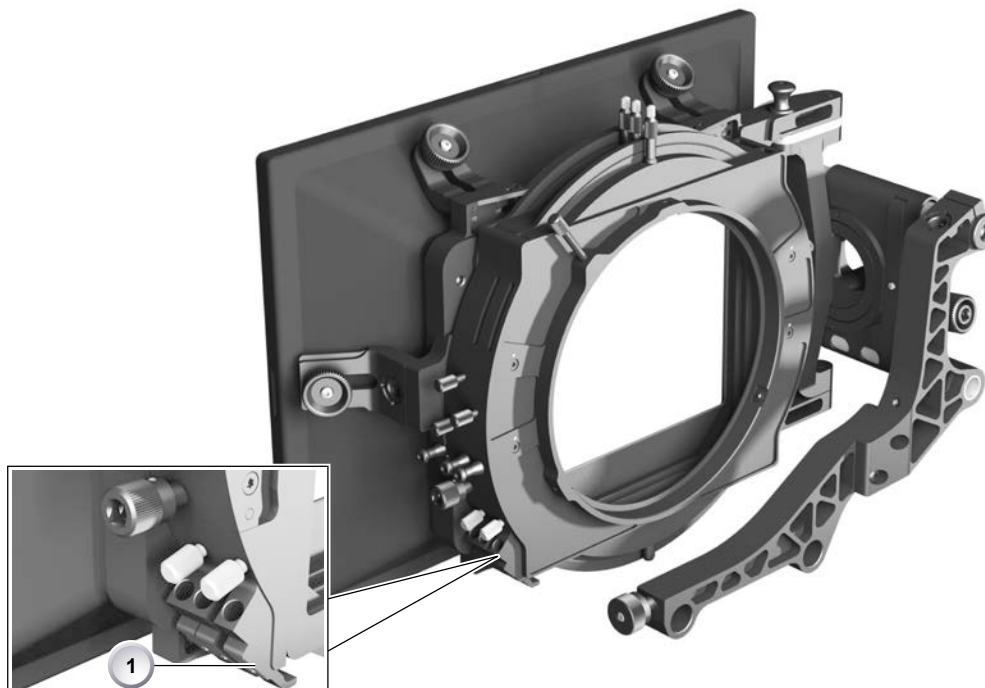

1. Slide the tray catcher (1) downwards.
2. **For filter movement (e.g., graduated filter):** Retract the tray catcher (1) upward.

# 11 Tilt and extension module

The Studio Matte Box Basic is fitted with an extension module with no tilt function. The Studio Matte Box Tilt is fitted with an integrated tilt and extension module.

## NOTICE

The integrated extension module of the basic version has no integrated tilt function.

## 11.1 Tilt module

### NOTICE

The tilt module features self lubricating components and should not be greased or oiled.

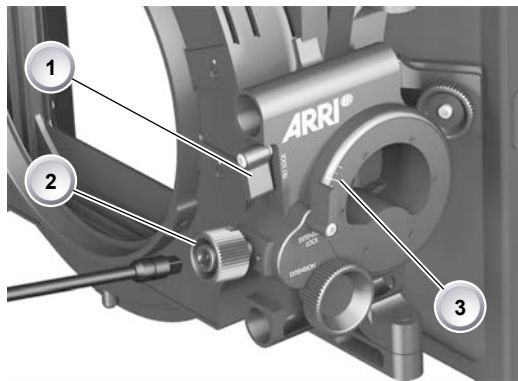

1. Fit the matte box to the camera rods.
2. Unlock the tilt module (1).
3. Turn the tilt control (2) anti-clockwise for tilt down and clockwise for tilt up.
4. When the required effect is achieved, lock the tilt module (1).
5. The angle between two graduations (3) is 5°. The limits of the tilt function are 20° down and 10° up.
6. The tilt control knob is compatible with the flexible shaft K2.34890.0 for behind-the-viewfinder operation.

### ⚠ CAUTION!

#### Risk of damage!

When tilting is done without the right extension, the filter stages and the studio arm might be damaged.

Before tilting, extend the matte box to the position where the desired tilting angle will not interfere with the studio arm.

## 11.2 Extension module



*Fig.: SMB-1 Basic*



*Fig.: SMB-1 Tilt*

1. Fit the matte box to the camera rods.
2. Unlock the extension module (1).
3. Move the matte box forward by turning the extension control (2) clockwise.
4. Move the matte box backwards by turning the extension control (2) anti-clockwise.
5. When the required extension is achieved, lock the extension module (1).



## 12 Flags

Articulated flags help to prevent stray light creating artifacts on the final image. The top/bottom flag fits to the top and bottom flag attachment of the matte box. Both sets of side flags fit to the side flag attachment.

### 12.1 Mounting/Removing the top/bottom flag

#### NOTICE

In order to fit the top/bottom flag at the bottom position, you should use the optional flag holders (pair) K2.0001517.

#### NOTICE

Each flag holder for the top and bottom flag can be repositioned by means of the two screws holding it to the matte box main frame in order to suit either the 4:3 or 2:1 sunshade.

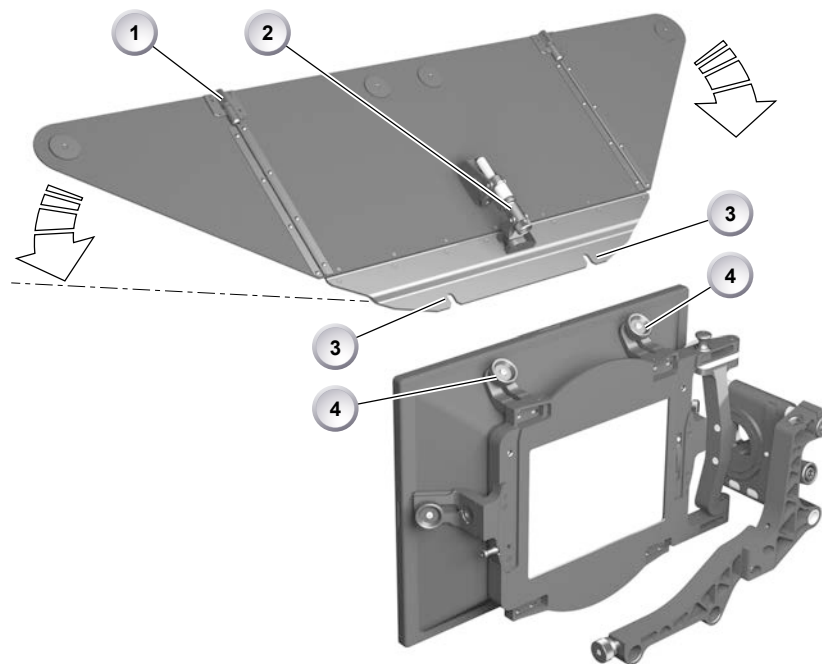

1. Open the two flag holder nuts (4) slightly until a gap of around 4 mm is visible.
2. Engage the top flag cut-outs (3) in the flag holder.
3. **To mount:** Lock the top flag in place by fastening the flag holder nut (4).
4. **To remove:** Open the two flag holder nuts (4) slightly and pull the top flag out.
5. Adjuster (2) for quick and fine adjust, see "Adjusting the flag angle", Page 26.

#### Top flag extensions

The matte box top flag is fitted with two collapsible extensions that can be deployed and retracted without the need to lock them in position. Just set a level of friction on the friction adjuster (1). This will keep the extension steady in closed, open and in between positions.

## 12.2 Mounting/Removing a side flag

### NOTICE

The following instruction is valid for both spherical and anamorphic side flags.

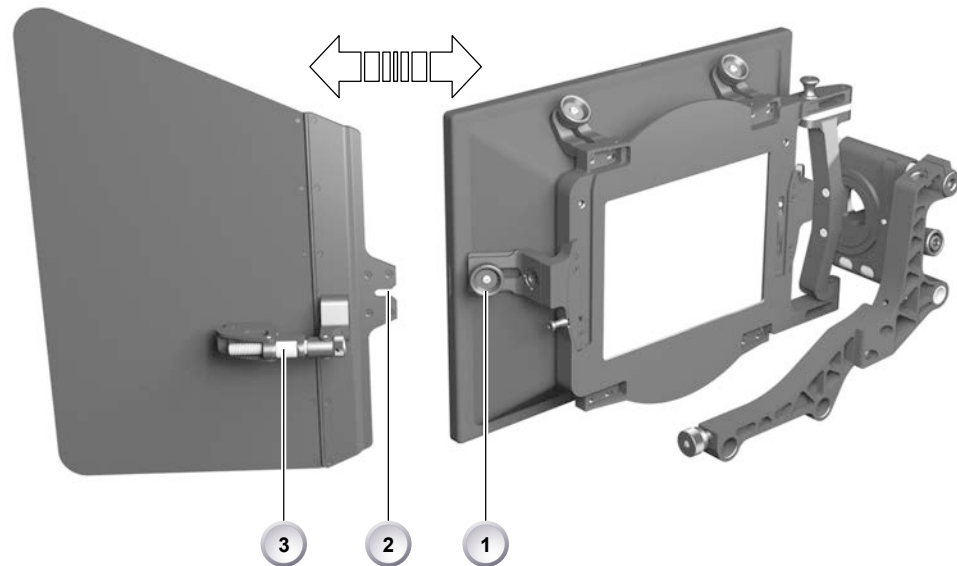

1. Open the flag holder nut (1) slightly until a gap of around 4 mm is visible.
2. Engage the side flag cut-out (2) in the flag holder.
3. **To mount:** Lock the side flag in place by fastening the flag holder nut (1).
4. **To remove:** Open the flag holder nut (1) slightly and pull the side flag out.
5. Adjuster (3) for quick and fine adjust, see "Adjusting the flag angle" .

## 12.3 Adjusting the flag angle

### ⚠ CAUTION!

#### Moving parts and hinges! Risk of injury!

Sharp edges may entail pinches.

Keep fingers away from potential pinching spots.

### NOTICE

The flag adjuster mechanism features self lubricating components and should not be greased or oiled.

All flags are fitted with adjusters for quick and fine adjustment.

- Use quick adjustment to reset the flag quickly, e.g., after work or if time is pressing.
- Use fine adjustment to precisely meet the camera format markings in order to optimise efficiency of the flag system.
- Fold flag adjusters only when fully retracted.

### 12.3.1 Quick adjust

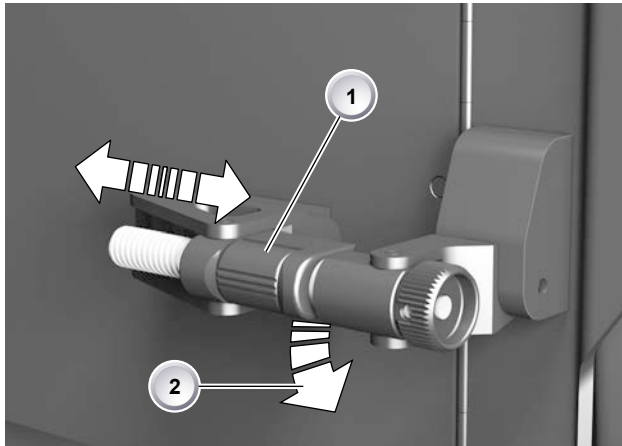

1. Lift the flag adjuster from its space-saving position (2).
2. Support the moving part of the flag with a hand.
3. Depress the quick adjust button (1) and keep depressed.
4. Adjust the flag angle to the desired position.
5. Release the quick adjust button (1).

### 12.3.2 Fine adjust

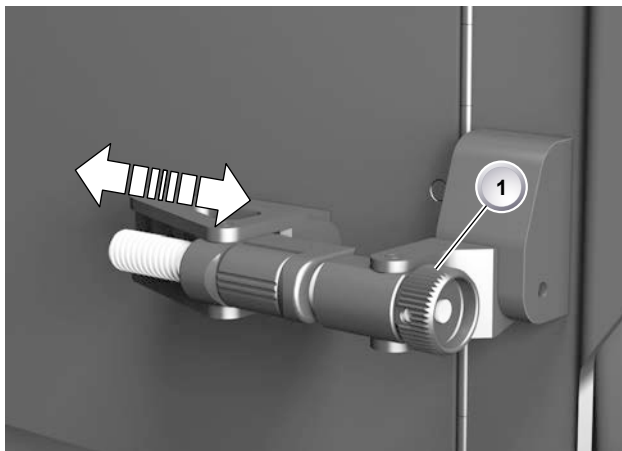

1. Turn the fine adjust knob (1) until the desired angle is reached:
  - Anti-clockwise for tilt down.
  - Clockwise for tilt up.

## 13 Mattes

Mattes help keeping stray light out of the lens front element.

Studio Matte Box mattes come in three variants:

- Mattes SPH (Spherical): Spherical mattes for 4:3 sunshade. Not compatible with 2:1 sunshade.
- Mattes SPH / ANAM: Anamorphic mattes for 4:3 sunshade. Not compatible with 2:1 sunshade.
- Mattes ANAM: Anamorphic mattes for 2:1 sunshade. Not compatible with 4:3 sunshade.

Each matte set includes five different mattes and a protective cover. All mattes are numbered. Matte #1 has the largest opening fitting wider angle lenses, matte #5 has the narrowest opening fitting longer lenses. Please test mattes with the lens/camera combination before the shoot.

### 13.1 Inserting a matte

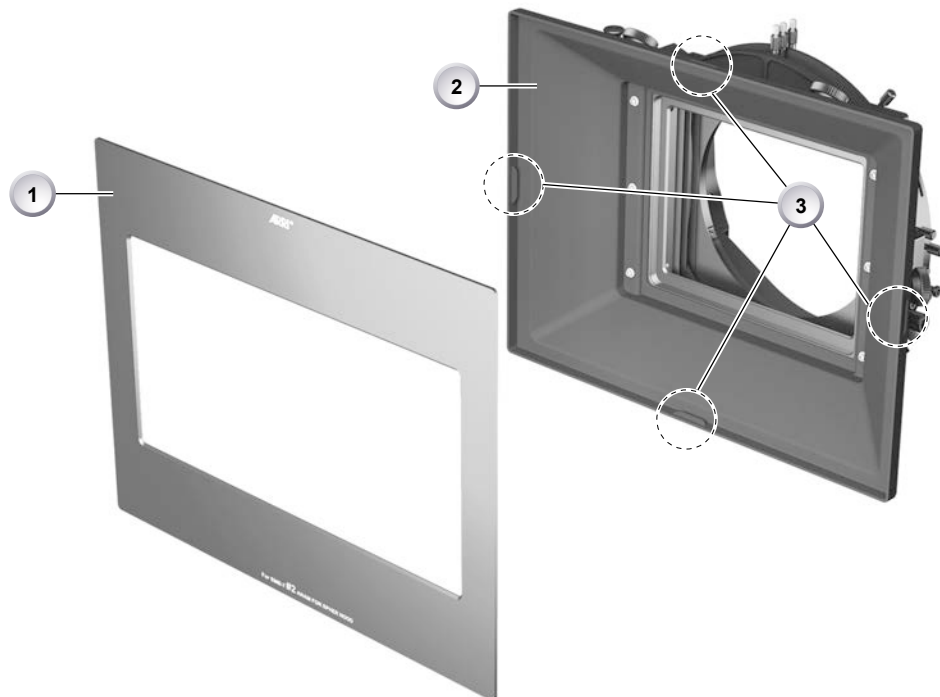

1. Fit the matte box to the camera rods.
2. Place the matte (1) of your choice at the front of the sunshade (2). The labelling of the matte must face away from the matte box with the ARRI logo on top.
3. Engage the matte (1) by pressing on the four catches (3) around the sunshade until they audibly lock.
4. **To remove:** Ease the matte (1) off the four catches (3) and pull it away from the sunshade (2).

## 13.2 Fitting a protective cover (matte #0)

To protect the lens, e.g., if moving the camera between shots or if leaving the camera unattended, each matte set includes a protective cover.

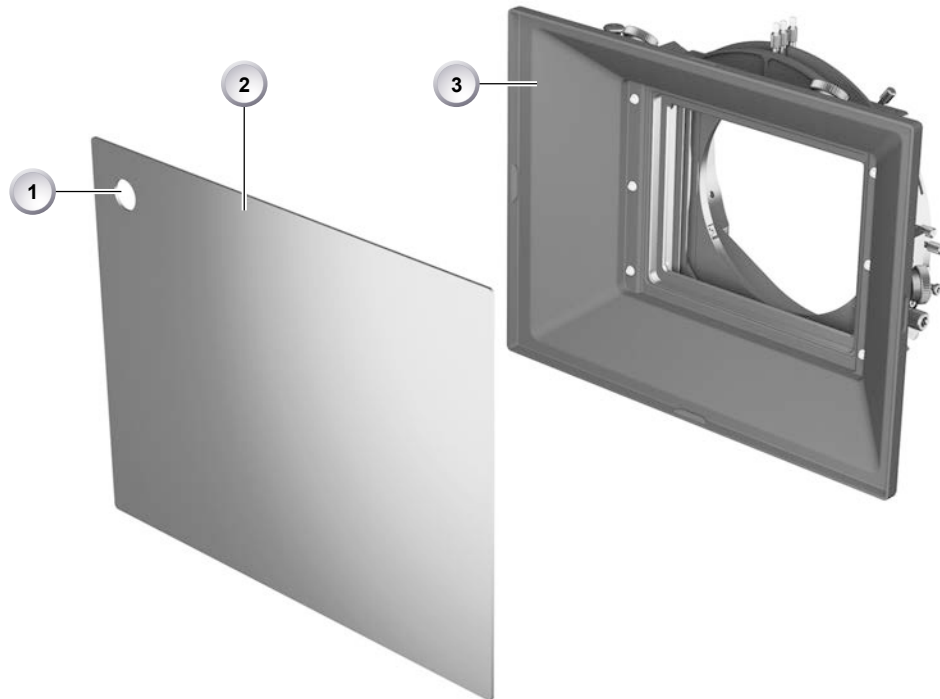

1. Fit the matte box to the camera rods.
2. Place and engage the protective cover (2) on the sunshade (3). See Page 28.
3. **To remove:** Engage a finger into the round aperture (1) and firmly pull the matte away from the sunshade.

## 14 Accessory adapter

An optional accessory adapter fits directly onto the matte box body. It can be used for french flag arms and incorporates a 3/8" - 16" sliding mount (e.g., for ultrasonic sensors such as the ARRI UDM-1).

### 14.1 Mounting/Removing an accessory adapter

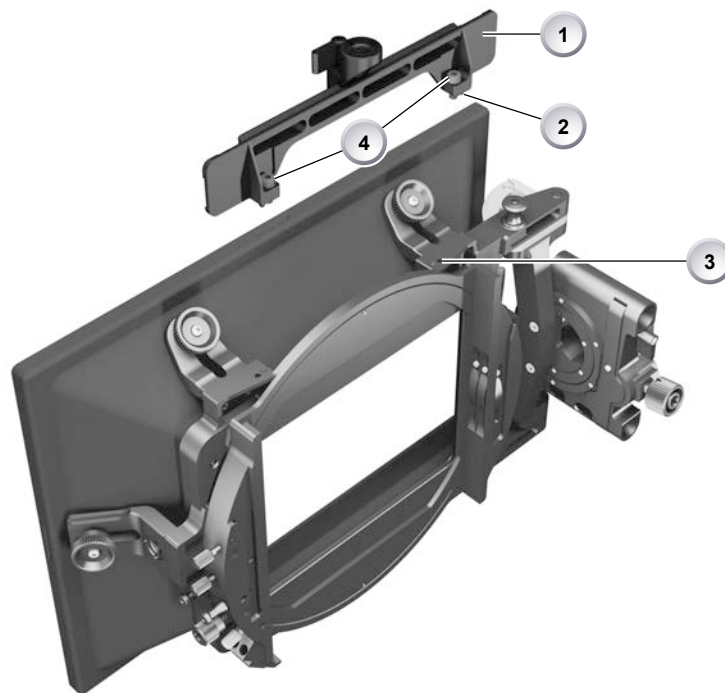

1. Fit the matte box to the camera rods or rest the matte box on its sunshade and arm.
2. Place the accessory adapter (1) on top of the matte box.
3. Engage the locating pins (2) into the slots (3) located on top of the matte box.
4. **To mount:** Tighten the two screws (4) with an 3 mm Hex driver.
5. **To remove:** Loosen the two screws (4) with an 3 mm Hex driver and pull off the accessory adapter (1).

## 14.2 Adapter operation

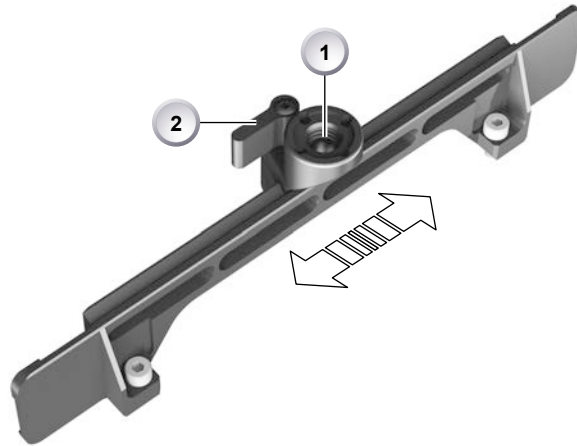

1. Unlock the 3/8" mount lock (2).
2. Slide the mount (1) to the desired position.
3. Lock the 3/8" mount lock (2).

Sprung ball bearings are located on each side of the accessory mount, preventing the accessory adapter to fall off. The accessory adapter can be removed (e.g., to be placed on another matte box) by pulling the accessory adapter firmly through the sprung ball bearings.

## 15 6" Tilting filter ring

A special rubber filter ring accompanies the matte box tilting module. The tilting filter ring comes as two similar size bellows that can be used as a single unit or stacked together for withstanding greater tilting angles. The filter ring can hold a round 6" filter and is compatible with Ø150mm (R8) screw-in rings.

### 15.1 Mounting/Removing the 6" tilting filter ring

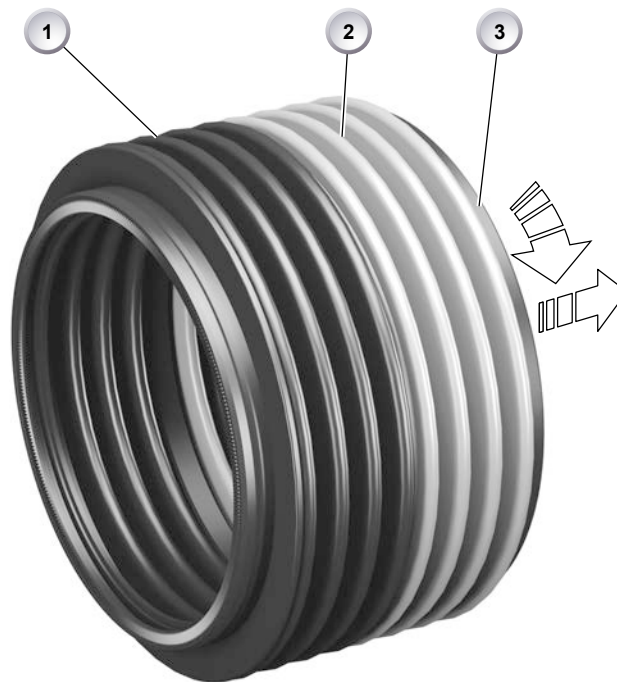

1. Engage the tilting filter ring (1) by pressing it into the filter stage until it audibly locks.
2. **To mount:** Lock the tilting filter ring (1) in position.
3. **To remove:** Unlock the tilting filter ring (1) and pull it off the filter stage.
4. **To separate:** Rotate both parts (1, 2) against each other in order to loosen the two halves.
5. For use with one half of the tilting filter ring, select the half that mounts to the matte box (1), and fit a screw-on lens ring (3) if required.